

## Termékjellemzők / Specifications

- ▶ Provide easy and faultless assembling
- ▶ Different assembling alternatives with versatile usage opportunities by a few pieces.
- ▶ Sash and frame can be fitted separately.  
Holes of the T&T Stay Arm Hinges and Stay Arm Bearing can be drilled by same jig.
- ▶ Systems parts are fixed in centered position to easy assembling.
- ▶ Stay arm can be used both for right and left hand opening by adjusting Stay Arm Hinge.
- ▶ It has superior corrosion protection with alkali zinc coating.
- ▶ Sash lifter on the Bottom Extension piece removes the problems caused by hang down of the window sash.
- ▶ Prevents the faulty usage in the tilt opening position by the standard system is set up on the Stay Arm.
- ▶ Mechanism on the Stay Arm reaches the clutching before 25 mm, during the sash is changed from tilt opening position to closed position.
- ▶ Faulty usage which can be added on the T&T Gear according to customer's demand, prevents faulty usage.
- ▶  $\pm 0,8$  mm pressure of the gasket can be adjusted by Eccentric Bolts and screws on the Bottom Extension Piece, Stay Arm, Drill in Corner Hinges.
- ▶ Horizontal position of the sash can be adjusted by screws on the Stay Arm and Corner Bearing.
- ▶ Vertical position of the sash can be adjusted by screw on the Drill in Corner Hinges.
- ▶ Security system parts can be used if the high security is wanted to theft.

MAX.	Width of the sash :1600 mm Height of the sash :2400 mm	
MIN.	Width of the sash : 286mm When the narrow side of the Small Transmission is used horizontal.  Height of the sash : 480mm When the narrow side of the Small Transmission is used vertical.	
	Width of the sash : 395mm When the narrow side of the Small Transmission is used vertical.  Height of the sash : 370mm When the narrow side of the Small Transmission is used vertical.	

**Attention! Measurements of the Sash Width and Sash Height was determined from espagnolette's canal.**

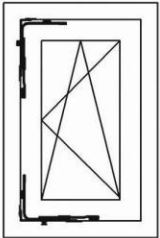
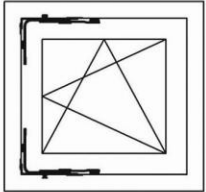
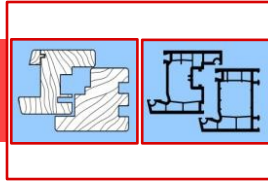

## Megengedett ablakszárny méretek

Max. Measurements of the Sash

Gear Systems with Variable Handle Height

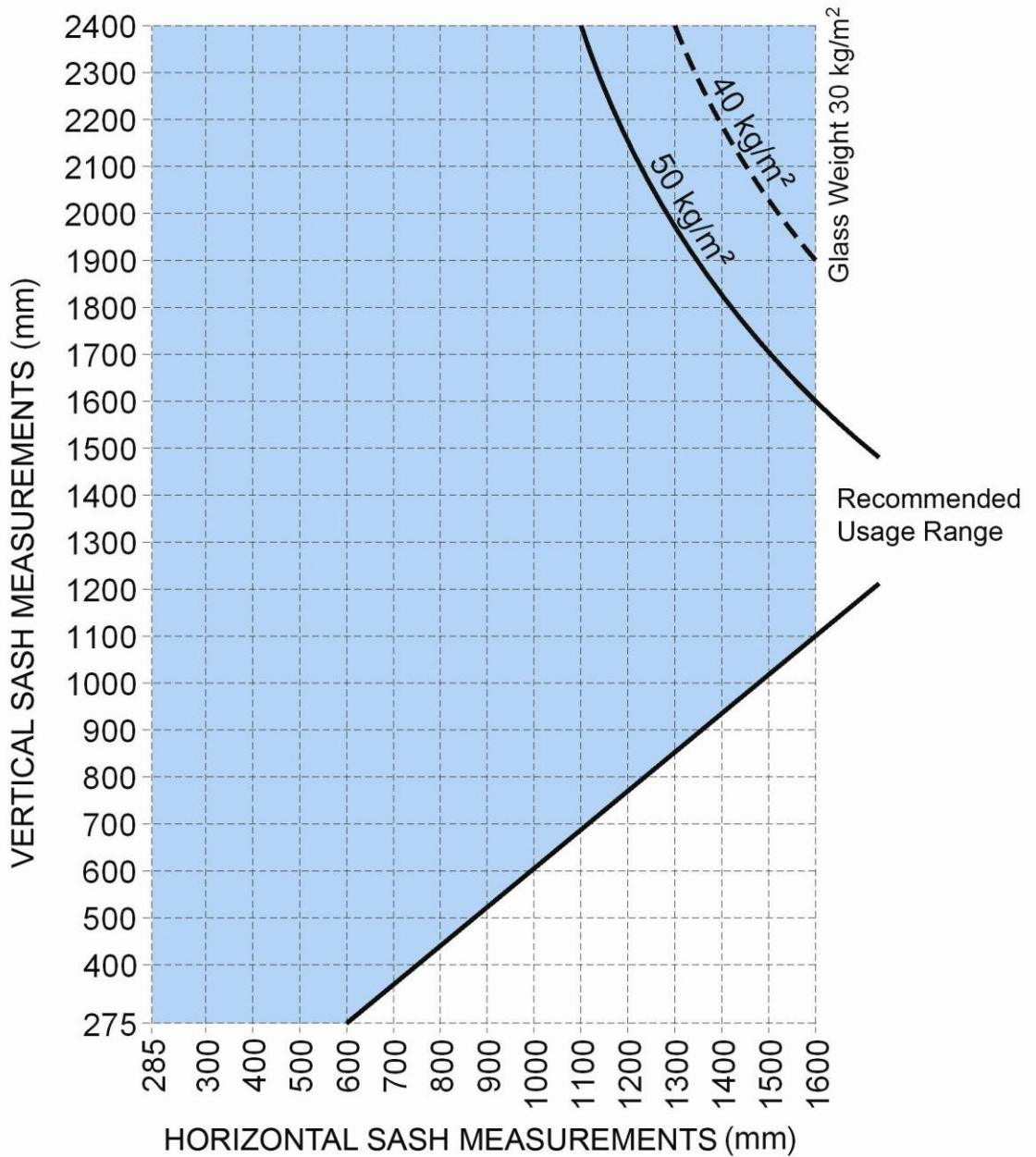

- ▶ Maximum sash weight must be 130 kg.
- ▶ Weigh of the glass is accepted 2,5 kg/m<sup>2</sup> for 1mm thickness.
- ▶ The measurements above may vary depending on the profile type.

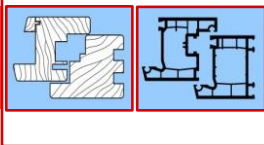

## A bukó-nyíló vasalat elemei

No	Terméknév		SRW/SRH		Termékkód
1	Bukó-nyíló rúdzár 15 mm-es tengelytávval	730	GR 01:585-1000	0	185010701
		1030	GR 02:885-1300	1	185011001
		1330	GR 03:1185-1600	1	185011301
		1530	GR 04:1385-1800	2	185011501
		1730	GR 05:1585-2000	2	185011701
2130	GR 06:1985-2400	2	185012101		
2	Bukó-nyíló rúdzár 7,5 mm-es tengelytávval	730	GR 01:585-1000	0	187010701
		1030	GR 02:885-1300	1	187011001
		1330	GR 03:1185-1600	1	187011301
		1530	GR 04:1385-1800	2	187011501
		1730	GR 05:1585-2000	2	187011701
2130	GR 06:1985-2400	2	187012101		
3	Összekötő rúdzár			1	189150601
4	Sarokváltó			1	181010001
5	Biztonsági sarokváltó			1	181020001
6	Sarokváltó, kisméretű			1	181030001
6-1	Biztonsági sarokváltó, kisméretű			1	181040001
7	Olló	465	GR 01:395-600	0	182010401
		665	GR 02:595-800	0	182010601
		865	GR 03:795-1000	1	182010801
		1065	GR 04:995-1200	1	182011001
		1265	GR 05:1195-1400	1	182011201
		1465	GR 06:1395-1600	1	182011401
8	Alsó hosszabító rúdzárhoz			1	184010001
9	Középzáró sarokváltóval	600	GR 01:700-1150	1	183010601
		800	GR 02:1150-1350	1	183010801
		1000	GR 03:1350-1850	2	183011001
		1400	GR 04:1850-2100	2	183011201
		1800	GR 05:2100-2400	3	183011401
10	Bukó-nyíló ollópánt	9-18			18604000*
		9-20			18605000*
		13-20			18608000*
11	Ollócsapágó				18603000*
12	Sarokpánt				18601000*
13	Sarokcsapágó				18602000*
14	Ollócsapágócsap				186120001
15	Ollópánt takaró				18920000*
16	Ollócsapágó takaró				18921000*
17	Sarokpánt takaró				18924000*
18	Sarokcsapágó takaró				18922000*
19	Sarokcsapágó alsó takaró				18923000*
20	Hibásműködésgátló				189250001
21	Bukó-nyíló zárfogadó				katalógus szerint
22	Bukó-nyíló biztonsági zárfogadó				katalógus szerint
23	Zárfogadó				katalógus szerint



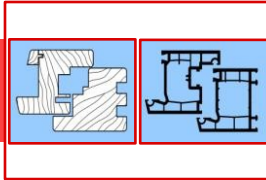

## Szerelési útmutató

### Fitting Instructions

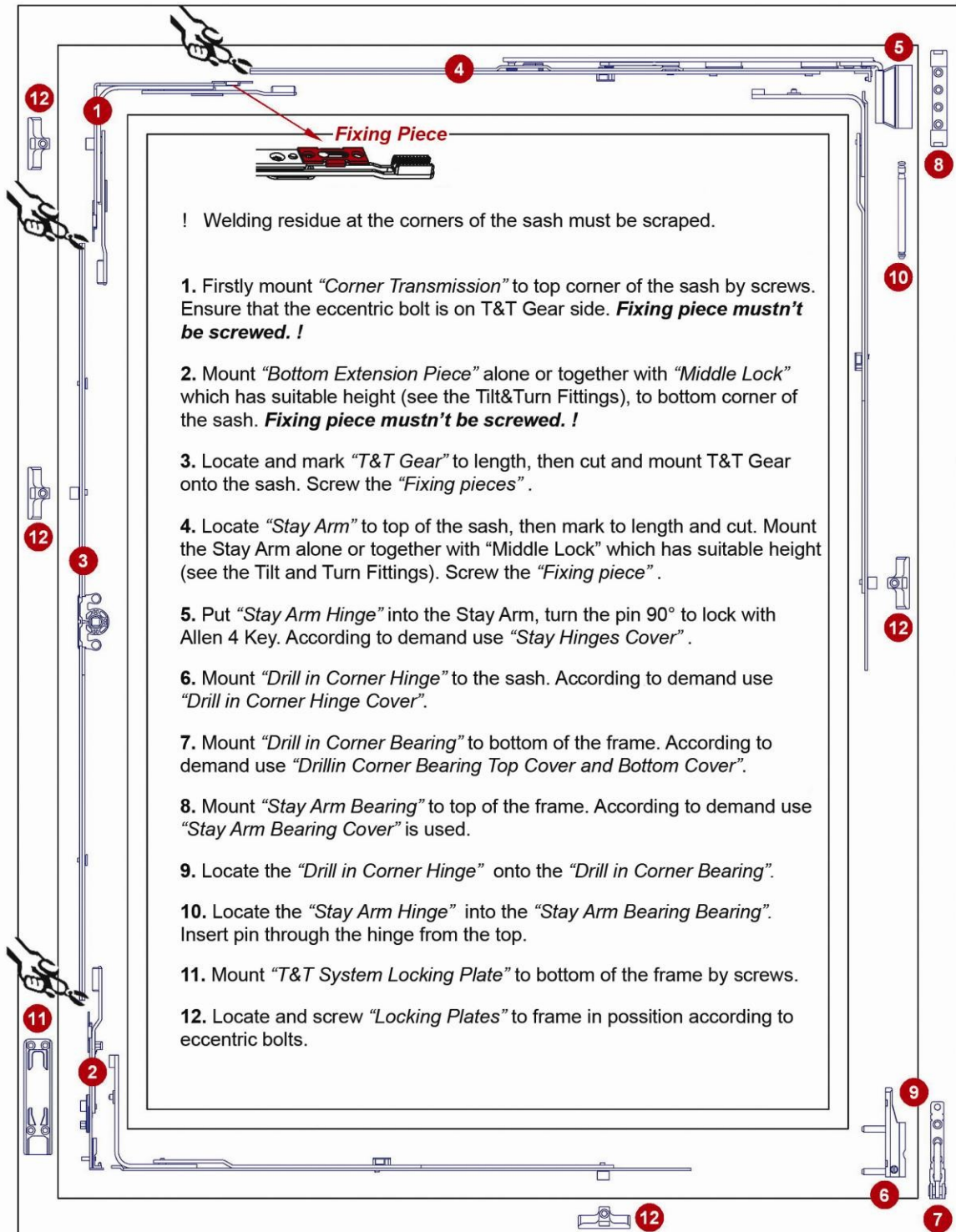

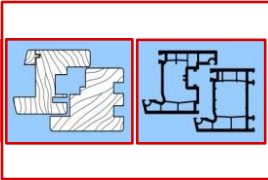

## A kilincs szerelésének előkészítése Preparing The Handle Holes

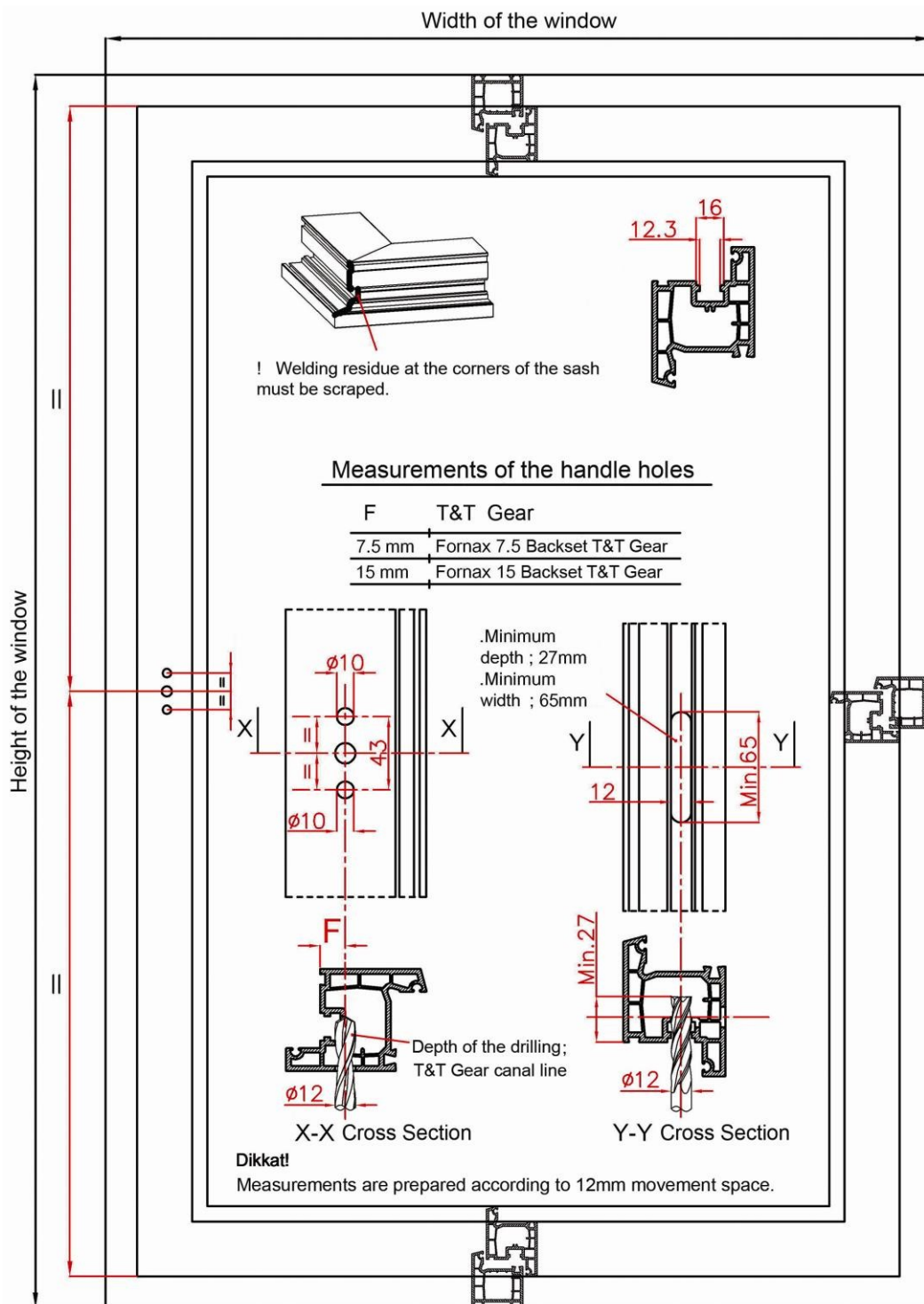

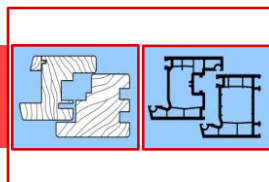

## Színskála Colour Scale

Színkód	Megnevezés (HU)	Product name (GB)
1	Ezüst	Silver
2	Sárga (EV3/Arany/Réz)	Yellow (EV3/Gold/Brass)
3	Ral 9016 Fehér	Ral 9016 White
4	Ral 8019 Sötét barna	Ral 8019 Dark Brown
5	Ral 8017 Barna	Ral 8017 Brown
6	Ral 8003 Világos barna	Ral 8003 Light Brown
7	Ral 1015 Bézs	Ral 1015 Beige
8	Ral 8022 Fekete	Ral 8022 Black
C	Egyedi szín	Special colours

### Magyarázat:

Néhány termék esetén a termékkód utolsó számjegye a színt jelöli.

Ha a termékkód utolsó számjegye (\*) szimbólumot tartalmaz, akkor ki kell választani a fenti táblázatból a kívánt színkódot, és azt kell behelyettesíteni A (\*) szimbólum helyére.

Példa: Ollócsapágó takaró: 18920000\*

A kívánt szín a fehér (Ral 9016).

A 3-as színkódot kell behelyettesíteni a (\*) helyére.

Ollócsapágó takaró (fehér színben): 189200003

r

### Explanation:

The last digit of some product code is the colour code.

If you see (\*) sign at the last digit of product code, you must choose colour on the colour scale, and write the colour code instead of the (\*) sign.

Example: Stay Arm Bearing Cover :18920000\*

Preferred colour is white (Ral 9016) on the colour scale.

Colour code 3 is written instead of the (\*).

Stay Arm Bearing Cover (White Ral 9016): 189200003

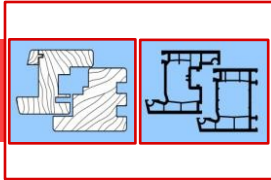



0101

## Bukó-nyíló rúdzár T&T Gear

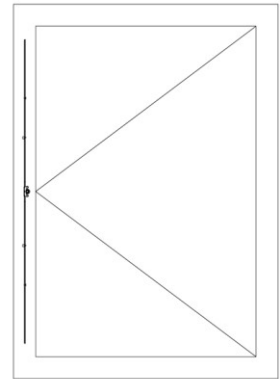
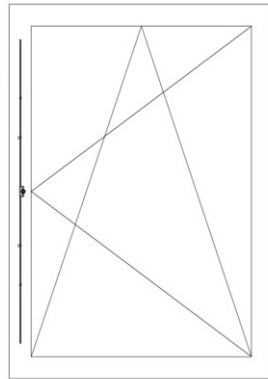
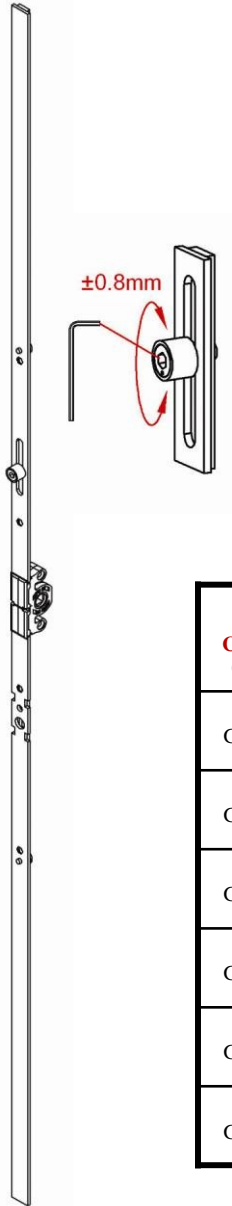
Back Set: 15mm



Csoport Group	Használati hossz Usage Length	Termék Product Code	A	B	C		
GR 01	585-1000	185010701	730	-	-	2	1
GR 02	885-1300	185011001	1030	120	-	4	1
GR 03	1185-1600	185011301	1330	120	-	6	2
GR 04	1385-1800	185011501	1530	272	272	8	2
GR 05	1585-2000	185011701	1730	322	322	8	2
GR 06	1985-2400	185012101	2130	372	372	10	2

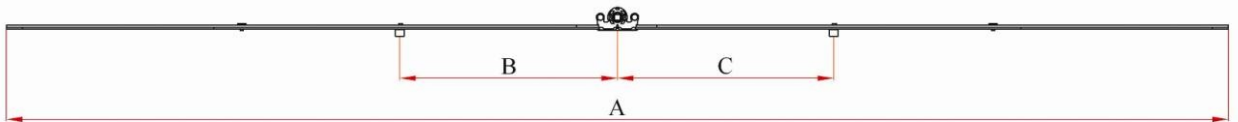

**Note:** Measurements are prepared in the open position.

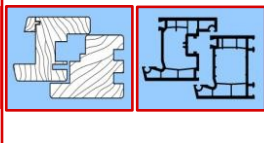



0102

## Bukó-nyíló rúdzár T&T Gear

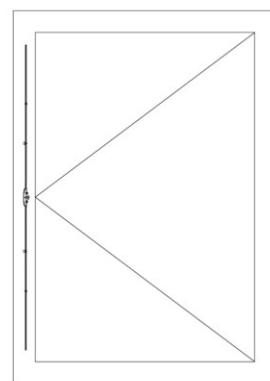
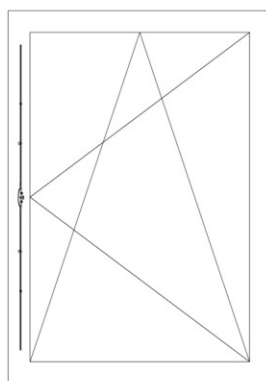
Back Set: 7,5mm



Group	Usage Length	Product Code	A	B	C		
GR 01	585-1000	187010701	730	-	-	2	1
GR 02	885-1300	187011001	1030	120	-	4	1
GR 03	1185-1600	187011301	1330	120	-	6	2
GR 04	1385-1800	187011501	1530	272	272	8	2
GR 05	1585-2000	187011701	1730	322	322	8	2
GR 06	1985-2400	187012101	2130	372	372	10	2

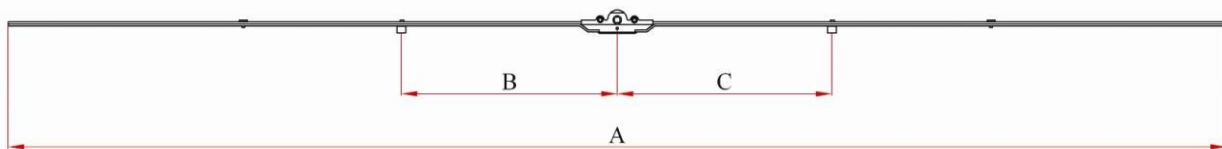

**Note:** Measurements are prepared in the the open position.



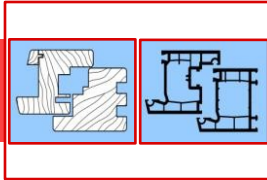

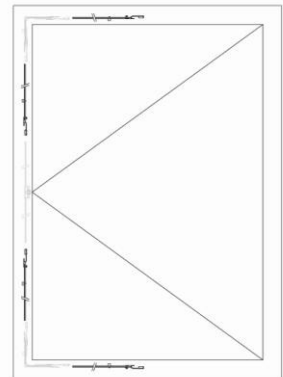
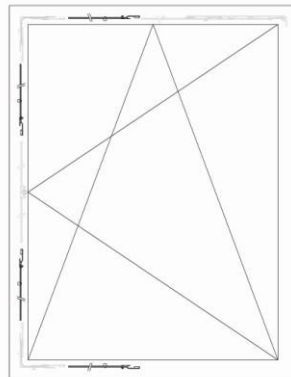

0103

## Összekötő rúdzár Connection Gear



Product Code		
189150601	4	1

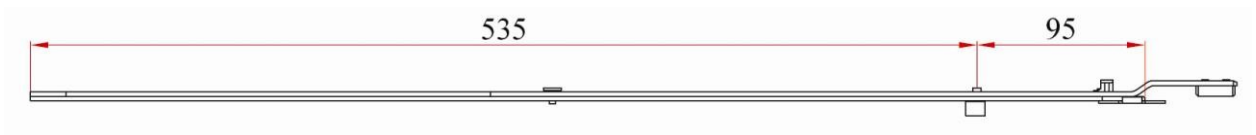

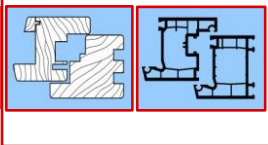

**Note:** Measurements are prepared in the the open position.

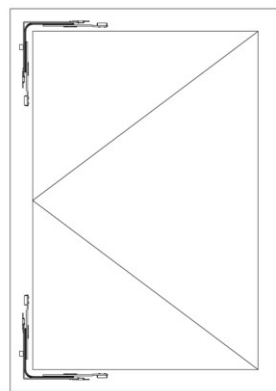
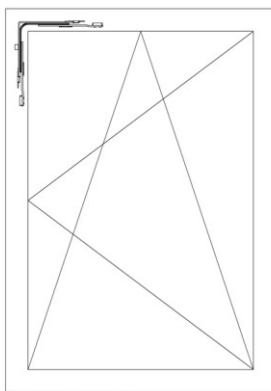
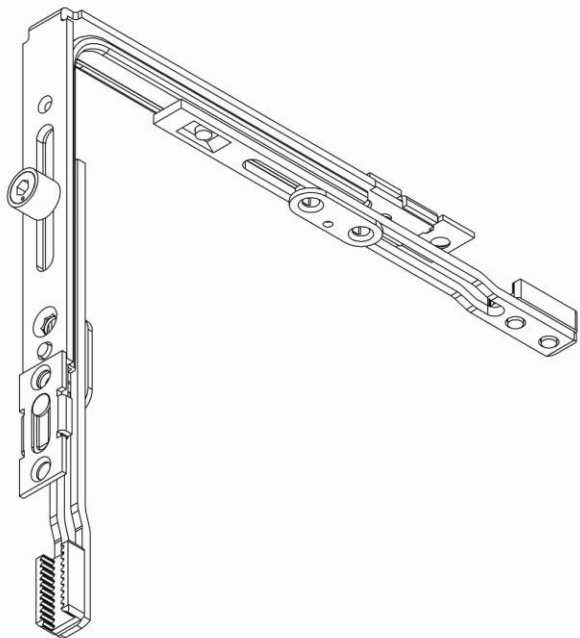

0201

## Sarokváltó Corner Transmission



Product Code		
181010001	6	1

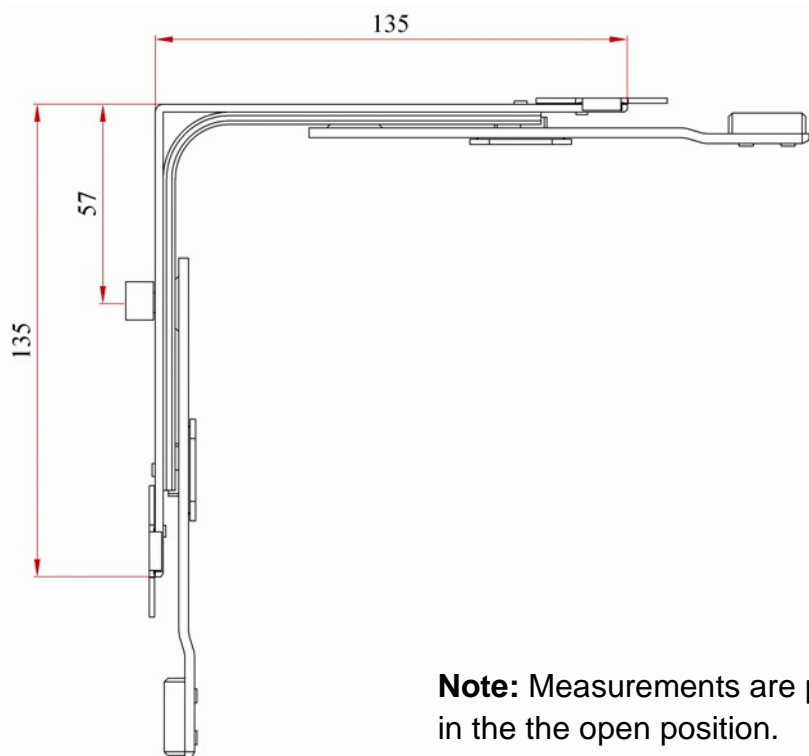

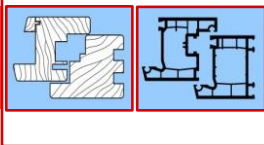

**Note:** Measurements are prepared in the the open position.

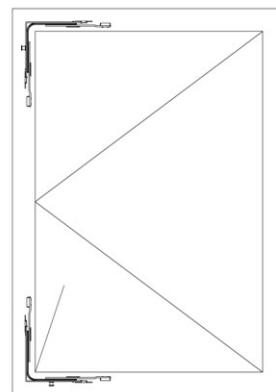
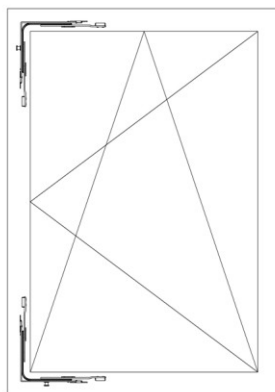
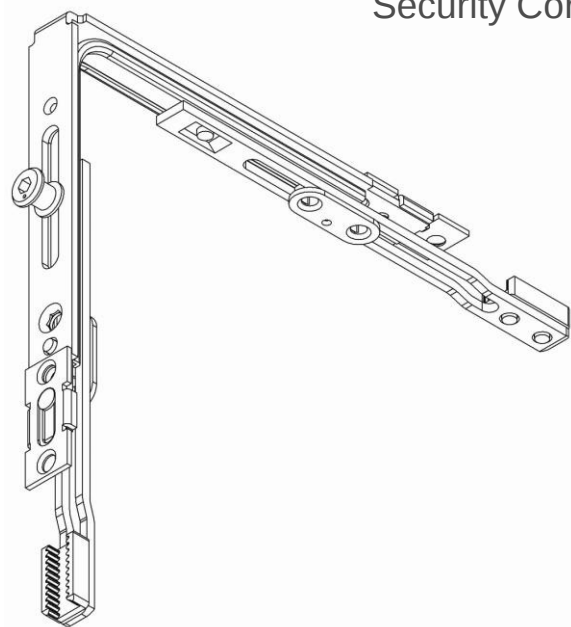

0202

## Biztonsági sarokváltó Security Corner Transmission

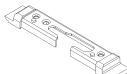

Product Code		
181020001	6	1

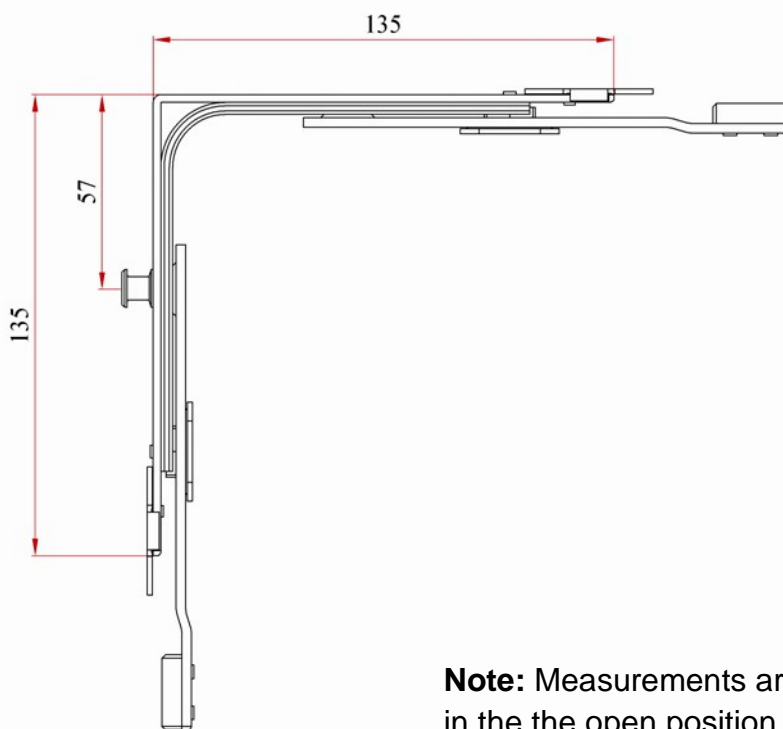

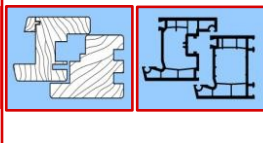

**Note:** Measurements are prepared in the the open position.

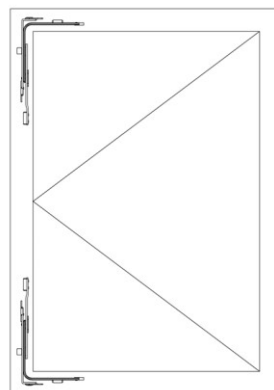
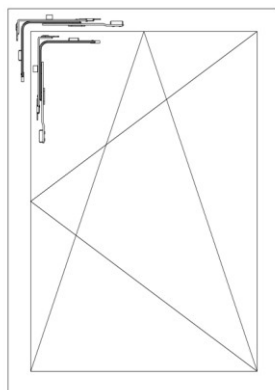
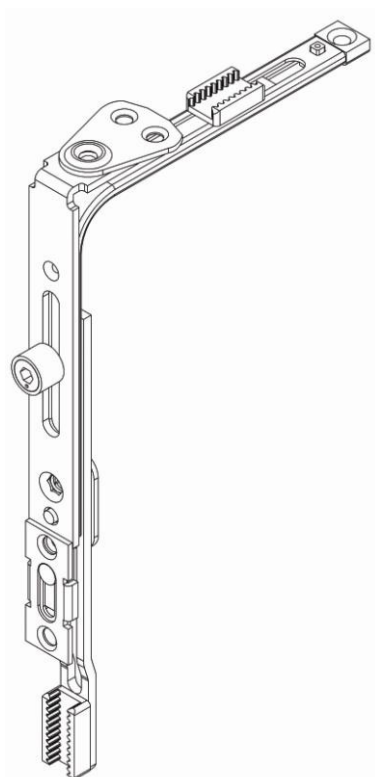

0203

## Sarokváltó, kis méretű Small Corner Transmission



Product Code		
181030001	5	1

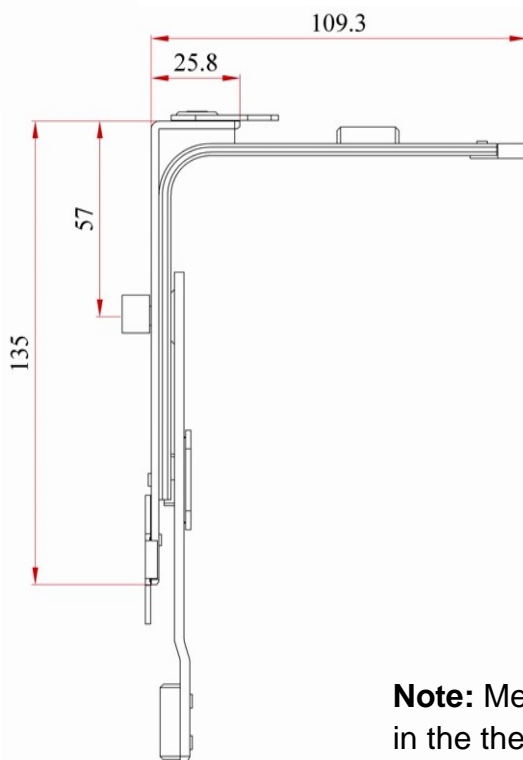

**Note:** Measurements are prepared in the the open position.

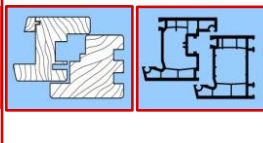



0203

## Biztonsági sarokváltó, kis méretű

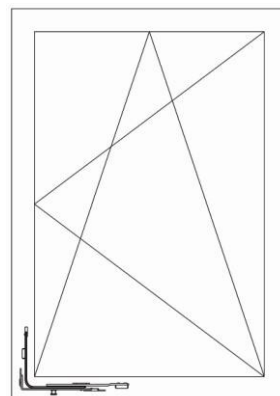
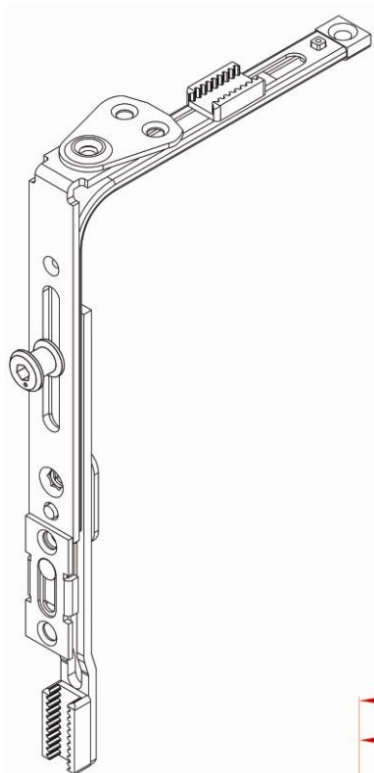
Security Small Corner Transmission



Product Code		
181040001	5	1

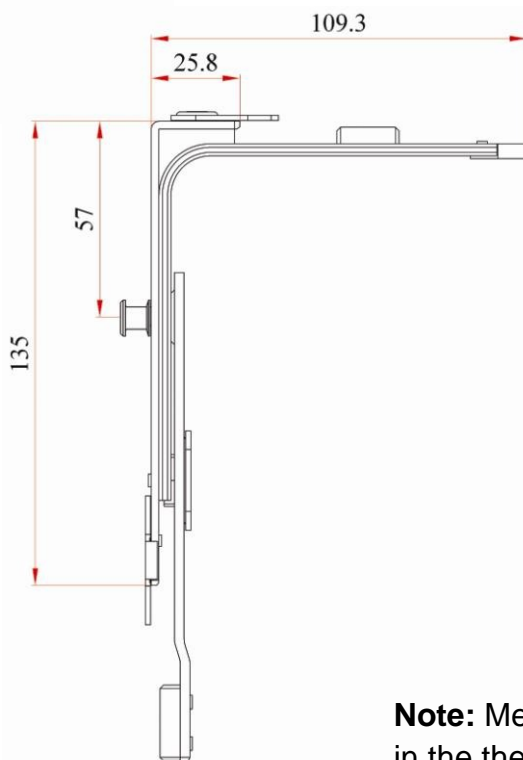

**Note:** Measurements are prepared in the the open position.



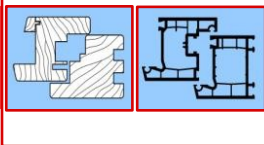

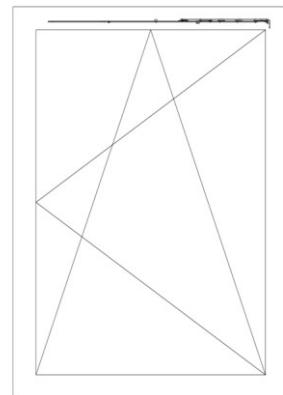

0301

## Olló Stay Arm



Group	Usage Length	Product Code	A	B		
GR 01	395-600	182010401	465	-	3	0
GR 02	595-800	182010601	665	-	5	0
GR 03	795-1000	182010801	865	542	7	1
GR 04	995-1200	182011001	1065	542	8	1
GR 05	1195-1400	182011201	1265	781	9	1
GR 06	1395-1600	182011401	1465	865	11	1

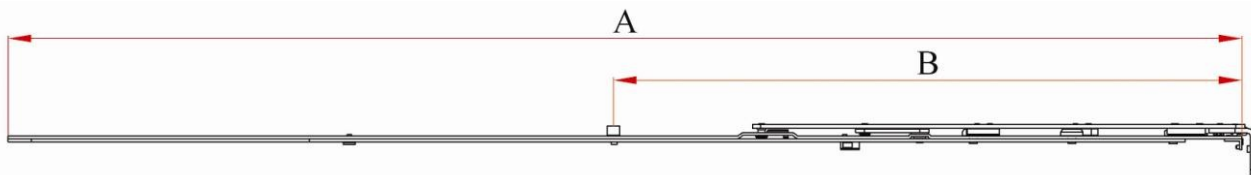

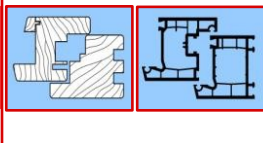

**Note:** Measurements are prepared in the the open position.

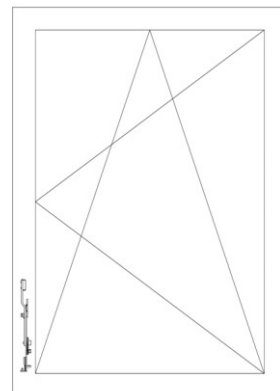
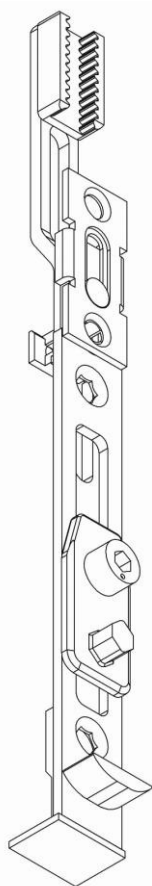

0401

**Alsó hosszabító rúdzárhoz**  
Bottom Extension Piece

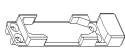

Product Code		
184010001	4	1

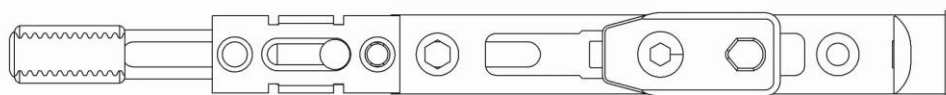
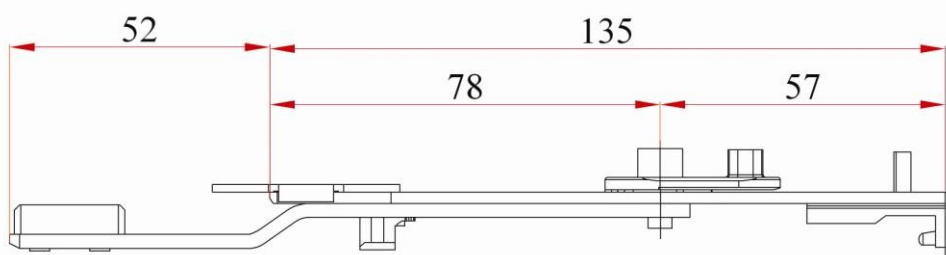

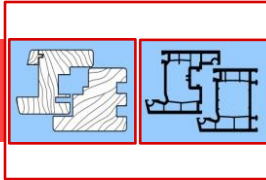

**Note:** Measurements are prepared in the the open position.

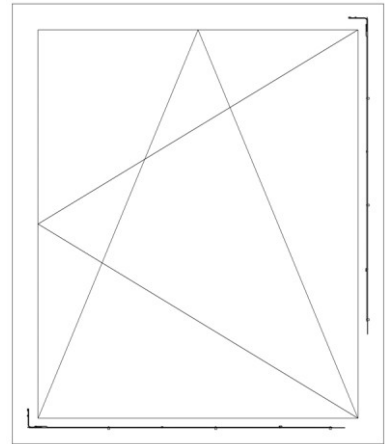
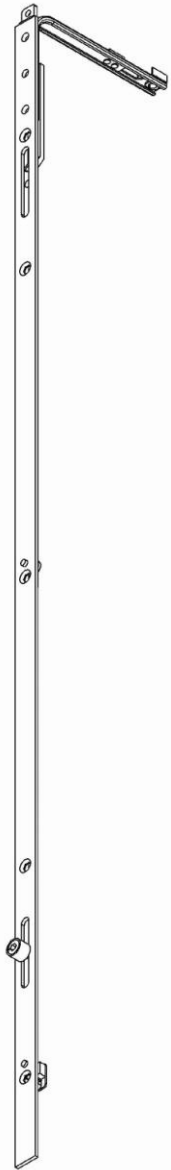

0501

## Középzáró sarokváltóval vízszintes/függőleges Middle Lock



Group	Usage Length	Product Code	Boy	A	B	C		
GR 01	700-1150	183010601	600	460	-	-	4	1
GR 02	1150-1350	183010801	800	660	-	-	5	1
GR 03	1350-1850	183011001	1000	460	700	-	7	2
GR 04	1850-2100	183011401	1400	674	730	-	8	2
GR 05	2100-2400	183011801	1800	460	600	643	10	3

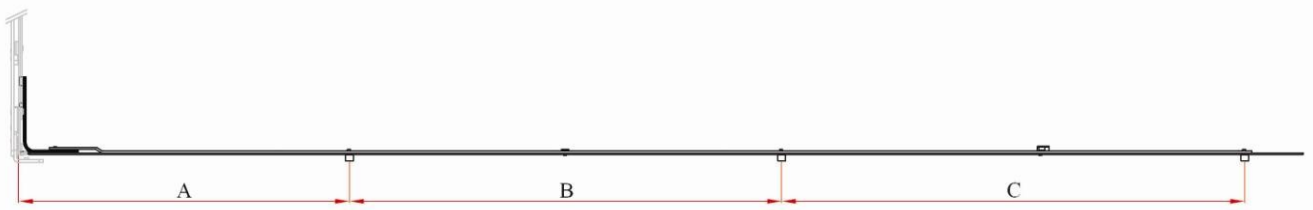

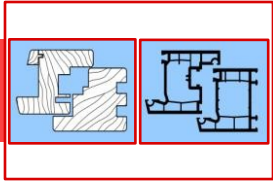

**Note:** Measurements are prepared in the open position.

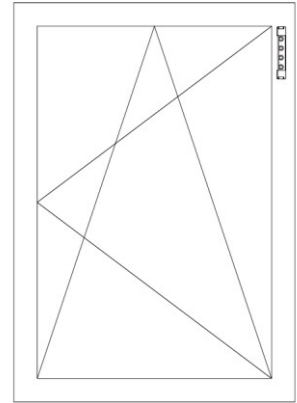
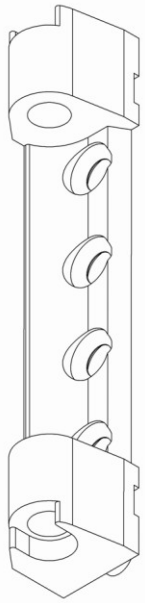

**0601**

**Ollócsapágy**  
T&T Stay Arm Bearing



<b>Product Code</b>	
18603000*	4

**Bukó-nyíló ollócsapágycsap / T&T Stay Arm Bearing Pin (Ø6mm)**

<b>Product Code</b>	
186120001	

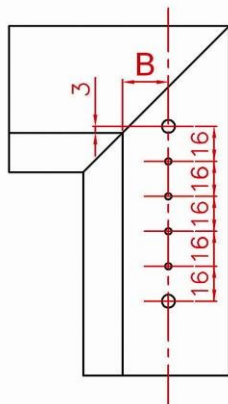

Sash overlap	(B)
18 mm	18.5 mm
20 mm	20.5 mm
22 mm	22.5 mm

**Stay Arm Bearing Holes ;**

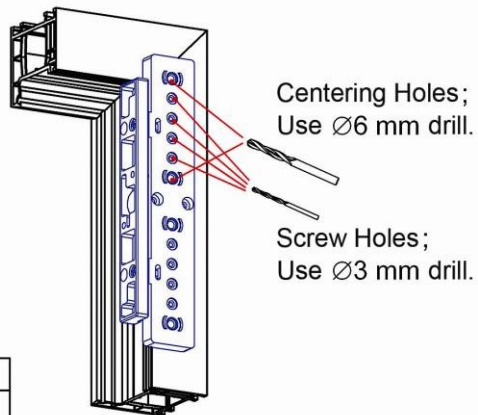

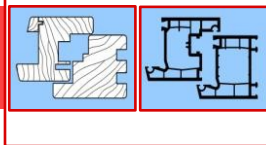

**0701**

## Bukó-nyíló olló pánt T&T Stay Arm Hinge

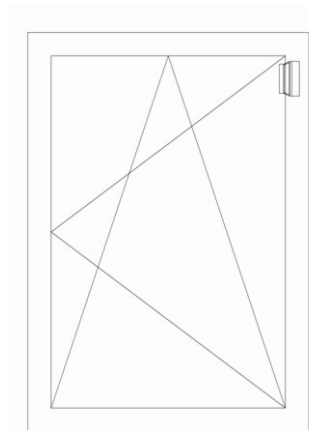
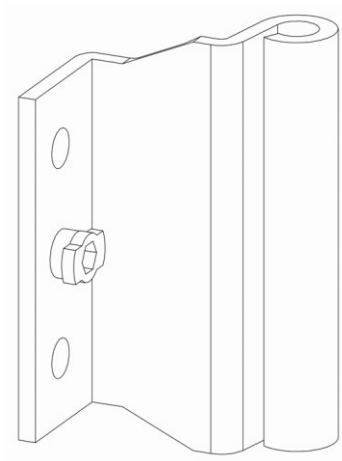

Product Code	Usage Length	A	B
18604000*	9-18	20,1	26
18605000*	9-20	20,1	28
18608000*	13-20	24,8	28

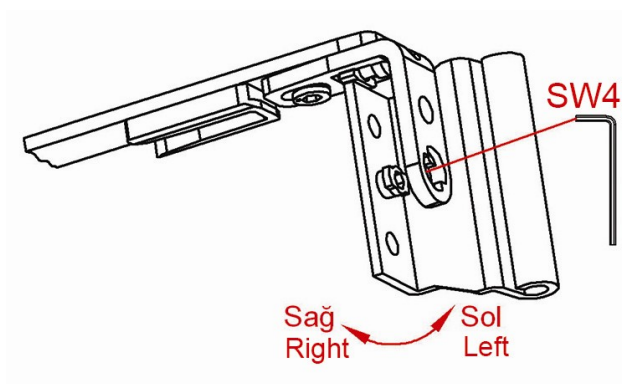
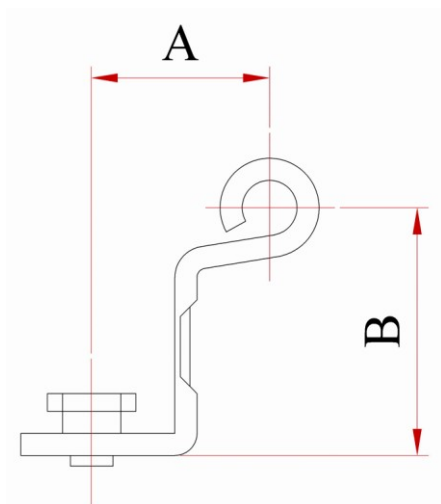



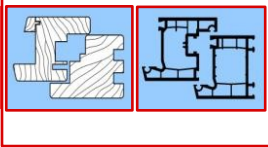

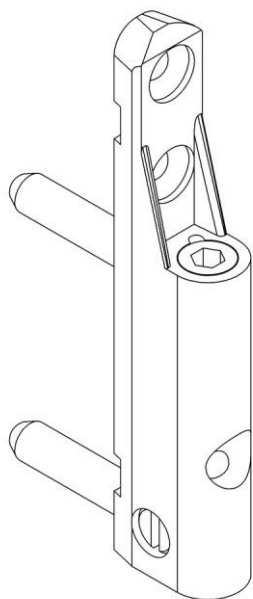

0801

## Sarokpánt Drill in Corner Hinge



<b>Product Code</b>	
18601000*	3

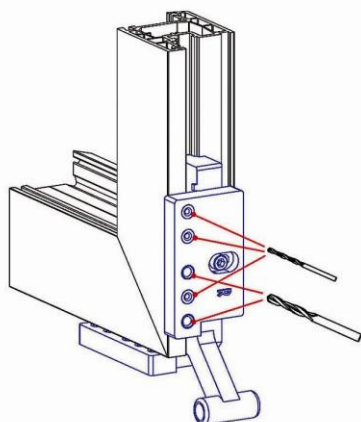
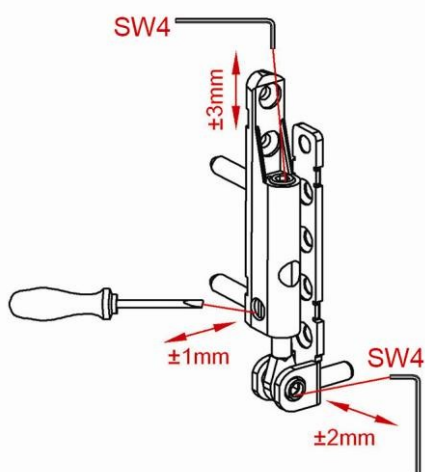
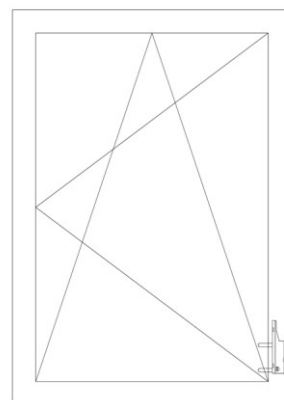

Sash overlap	(A)
18 mm	22,5 mm
20 mm	24,5 mm
22 mm	26,5 mm

Screw Holes;  
Use  $\varnothing 3$  mm drill.

Centering Holes;  
Use  $\varnothing 6$  mm drill.

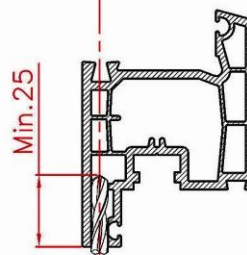
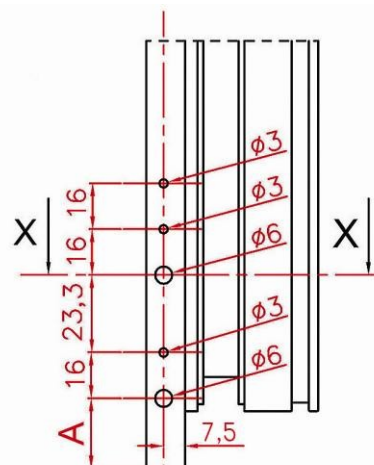

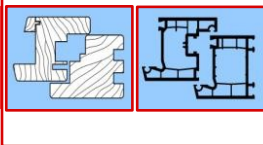

X-X Cross Section

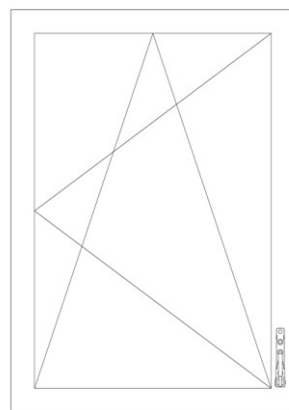
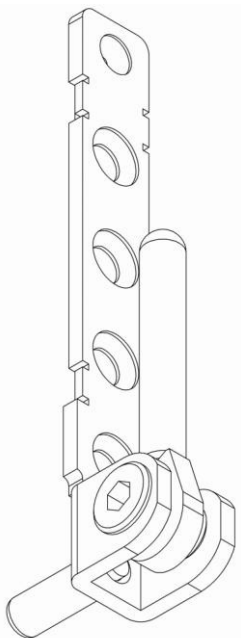

**0901**

## Sarokcsapágy Corner Bearing



<b>Product Code</b>	
18602000*	4

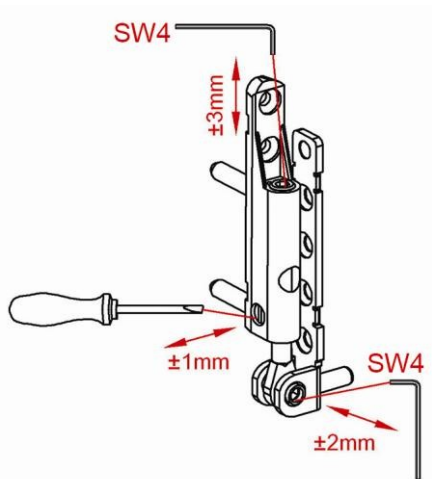

Sash overlap	( B )
18 mm	18.5 mm
20 mm	20.5 mm
22 mm	22.5 mm

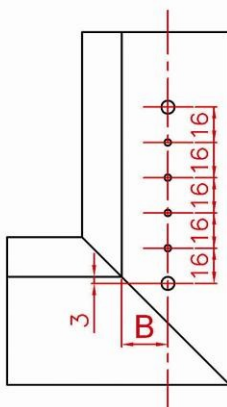

### Corner Bearing Holes;

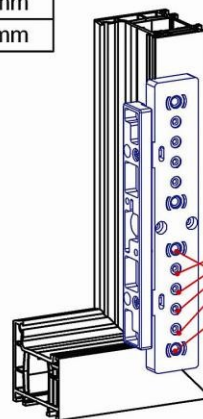

Screw Holes;  
Use  $\varnothing 3$  mm drill.

Centering Holes;  
Use  $\varnothing 6$  mm drill.

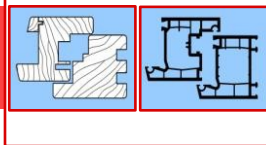

1001

## Takaró elemek Covers

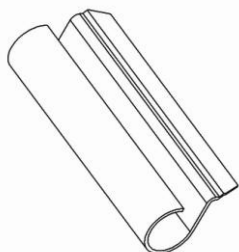

Termék Product	Termékkód Product Code
Ollópánt takaró T&T Stay Arm Hinge Cover	18920000*

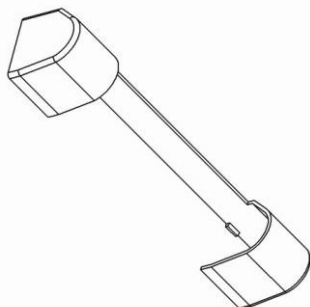

Termék Product	Termékkód Product Code
Ollócsapágó takaró T&T Stay Arm Bearing Cover	18921000*

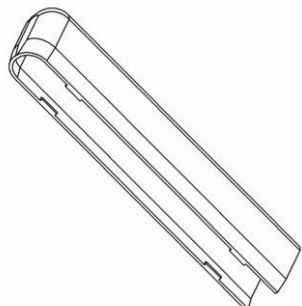

Termék Product	Termékkód Product Code
Sarokpánt takaró Drill in Corner Hinge Cover	18924000*

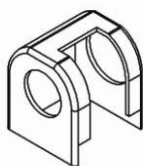

Termék Product	Termékkód Product Code
Sarokpánt alsó takaró Corner Bearing Bottom Cover	18922000*

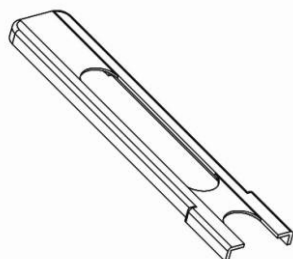

Termék Product	Termékkód Product Code
Ollócsapágó takaró Corner Bearing Top Cover	18923000*

\* Lásd színskálát / See Colour Scale

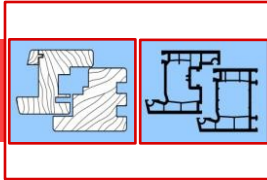

11 01

## Bukó-nyíló biztonsági zárfogadó T&T System Security Locking Plates

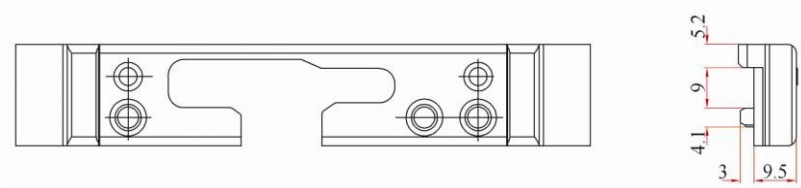
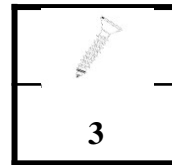
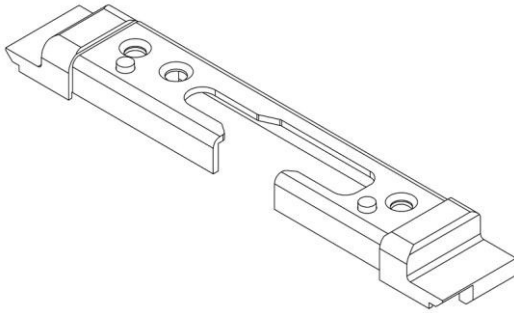

Termék Product	Termékkód Product Code
13L	1890700L1

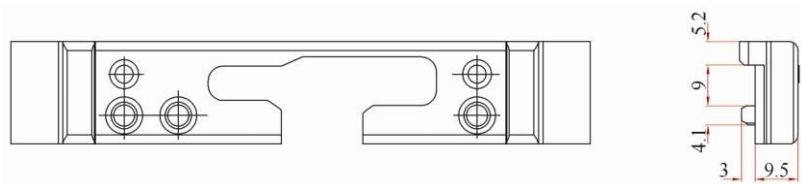

Termék Product	Termékkód Product Code
13R	1890700R1

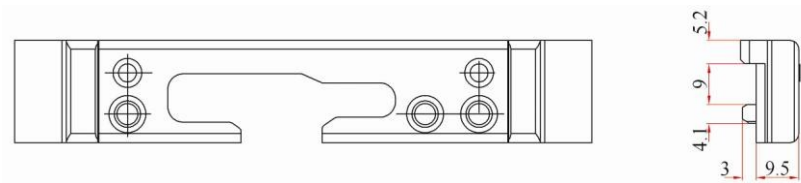

Termék Product	Termékkód Product Code
9L	1890500L1

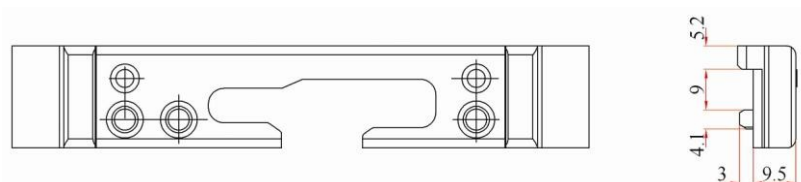

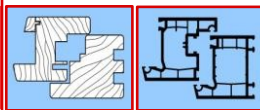

Termék Product	Termékkód Product Code
9R	1890500R1



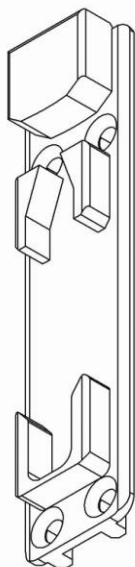

11 02

## Bukó-nyíló zárfogadó T&T System Locking Plates

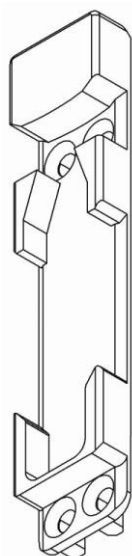
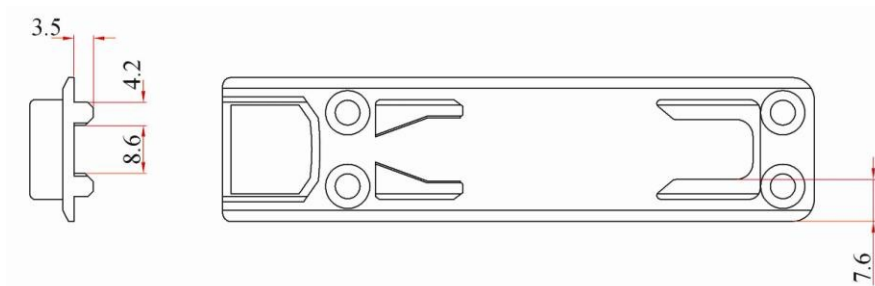

<b>Termék</b> Product	<b>Termékkód</b> Product Code	
<b>13 R-L T&amp;T LOCKING PLATE</b>	<b>189160001</b>	<b>4</b>



<b>Termék</b> Product	<b>Termékkód</b> Product Code	
<b>9 R-L T&amp;T LOCKING PLATE</b>	<b>189170001</b>	<b>4</b>

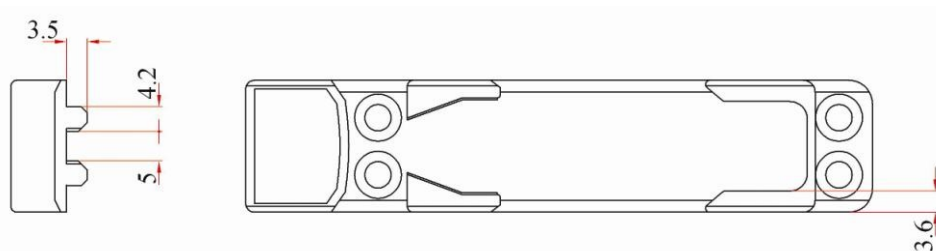



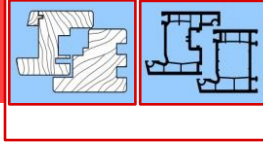

11 03

## Ablakrendszerek listája

### List of Profiles

PROFIL LIST PROFILE LIST	SERIAL	SASH OVERLAP	T & T LOCKING PLATE	T & T SECURITY LOCKING PLATE
ADOPEN	Akdeniz 70 mm 632 (Wintech) 642 (Wintech)	13	189160001	1890700L/R1
AKANSUPEN	Aksu Süper Vena Vena	9 13 13	189170001 189160001 189160001	1890500L/R1 1890700L/R1 1890700L/R1
AKAPEN	Avantaj Vega	13	189160001	1890700L/R1
ALFAPEN	Venüs Işın	9	189170001	1890500L/R1
ALUPLAST	IDEAL 2000 AD 60 IDEAL 4000 AD 70 IDEAL 5000 MD 70 IDEAL 6000 MD 80 IDEAL 7000 AD 80	13	189160001	1890700L/R1
ARTPLAST	70 mm AD	13	189160001	1890700L/R1
ASAŞPEN	6040 6000 5200	13 9 9	189160001 189170001 189170001	1890700L/R1 1890500L/R1 1890500L/R1
BOIWIN	Larc	13	189160001	1890700L/R1
BİRPEN		13	189160001	1890700L/R1
BRUGMAN AD/MD	73 mm	13	189160001	1890700L/R1
CANKARPEN		13	189160001	1890700L/R1
DIMEX	70 mm 60 mm	13	189160001	1890700L/R1
DOORWIN		13	189160001	1890700L/R1
DURUPEN		13	189160001	1890700L/R1
EGEPEN	Zendow Sistem (2032) Everest	13 13 9	189160001 189160001 189170001	1890700L/R1 1890700L/R1 1890500L/R1

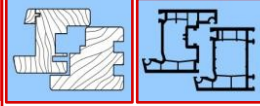

## Ablakrendszerek listája

### List of Profiles

PROFIL LIST	SERIAL	SASH OVERLAP	T & T LOCKING PLATE	T & T SECURITY LOCKING PLATE
ENDERPEN	70 mm	13	189160001	1890700L/R1
	Vizyonline Ultra			
ERPEN	Vizyonline	13	189160001	1890700L/R1
	56 mm	13	189160001	1890700L/R1
	Extraline	9	189170001	1890500L/R1
	Smartline	9	189170001	1890500L/R1
ESENPEN	Ecoline	13	189160001	1890700L/R1
	Softline			
EUROLINE	Milenyum	13	189160001	1890700L/R1
	58 mm Lük			
EUROPEN	58 mm Ekonomik	9	189170001	1890500L/R1
	Elite			
EUROWIN	Fiesta	13	189160001	1890700L/R1
FİLPEN	UZAY	13	189160001	1890700L/R1
FIRATPEN		9	189170001	1890500L/R1
FLASHPEN		13	189160001	1890700L/R1
GEALAN		13	189160001	1890700L/R1
GÜNELPEN	BEGONIA	9	189170001	1890500L/R1
	MAGNOLIA	9	189170001	1890500L/R1
	AZALEA	13	189160001	1890700L/R1
KARPEN		13	189160001	1890700L/R1
KBE	58 mm	9	189170001	1890500L/R1
	70 mm	13	189160001	1890700L/R1
KEBANPEN	600 EKO SERİ	9	189170001	1890500L/R1
	6002 SÜPER SERİ	13	189160001	1890700L/R1
KNIPPING		13	189160001	1890700L/R1
KOMPEN	200 SUPERLINE	9	189170001	1890500L/R1
	300 MEGALINE	9	189170001	1890500L/R1
	600 TERMOLINE	13	189160001	1890700L/R1

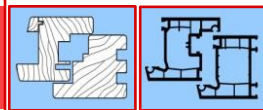

## Ablakrendszerek listája

### List of Profiles

PROFIL LIST	SERIAL	SASH OVERLAP	T & T LOCKING PLATE	T & T SECURITY LOCKING PLATE
<b>KOMMERLING</b>	<i>Classic AD 70 Classic MD 70 Elegance AD 70 MD 80 58 mm</i>	13	189160001	1890700L/R1
<b>MYWIN</b>		13	189160001	1890700L/R1
<b>NATUREL</b>	<i>SUPERNAT</i>	13	189160001	1890700L/R1
<b>ÖNDERPEN</b>		9	189170001	1890500L/R1
<b>ÖRNEKPEN</b>		9	189170001	1890500L/R1
<b>ÖZENİŞPEN</b>		9	189170001	1890500L/R1
<b>PAKPEN</b>	<i>UNIVERSAL P-200 EKO OVAL</i>	9	189170001	1890500L/R1
<b>PENSA</b>		13	189160001	1890700L/R1
<b>PARPLAST</b>	<i>6032 6042</i>	13	189160001	1890700L/R1
<b>PENTECH</b>		9	189170001	1890500L/R1
<b>PİMAPEN</b>	<i>6000</i>	9	189170001	1890500L/R1
	<i>5300</i>	9	189170001	1890500L/R1
	<i>4500</i>	9	189170001	1890500L/R1
	<i>QUADRO</i>	13	189160001	1890700L/R1
	<i>7000</i>	13	189160001	1890700L/R1
	<i>7500</i>	13	189160001	1890700L/R1
<b>PLASPEN</b>		9	189170001	1890500L/R1
<b>POLİPEN</b>		13	189160001	1890700L/R1
<b>PROKAL</b>		13	189160001	1890700L/R1
<b>PROLINE</b>		13	189160001	1890700L/R1
<b>RAMPLAST</b>		9	189170001	1890500L/R1
<b>REHAU</b>	<i>BRILLIANT-DESIGN AD 70 BASIC-DESIGN AD 60 THERMO-DESIGN AD 60</i>	13	189160001	1890700L/R1

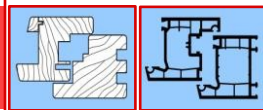

11 03

## Ablakrenszerek listája

List of Profiles

PROFIL LIST	SERIAL	SASH OVERLAP	T & T LOCKING PLATE	T & T SECURITY LOCKING PLATE
RESMAN		13	189160001	1890700L/R1
ROPLASTO	7001 AD	13	189160001	1890700L/R1
ROTHOPLAST		13	189160001	1890700L/R1
SALAMANDER	2D 3D	13	189160001	1890700L/R1
SARAYPEN		13	189160001	1890700L/R1
SEÇPEN		9	189170001	1890500L/R1
SCHÖNLINIE	70 mm EKOLINE 60 mm	13	189160001	1890700L/R1
STARPEN		9	189170001	1890500L/R1
TAURUS		13	189160001	1890700L/R1
TEKNO PLAST		13	189160001	1890700L/R1
TROCAL		13	189160001	1890700L/R1
UNIPLAST		13	189160001	1890700L/R1
VEKA	Softline AD 70 Topline AD 70 Softline AD 58	13	189160001	1890700L/R1
WINAPEX		13	189160001	1890700L/R1
WINDER		9	189170001	1890500L/R1
WINDOLINE		13	189160001	1890700L/R1
WINHOUSE		9	189170001	1890500L/R1
WINPLAST		9	189170001	1890500L/R1
WORLDPEN		13	189160001	1890700L/R1
WYMAR		13	189160001	1890700L/R1
YILDIZPEN		9	189170001	1890500L/R1



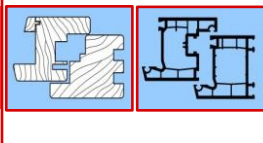

1201

### Fúrósablon sarokpánthoz

Drilling Jig for Drill in Corner Hinge Holes

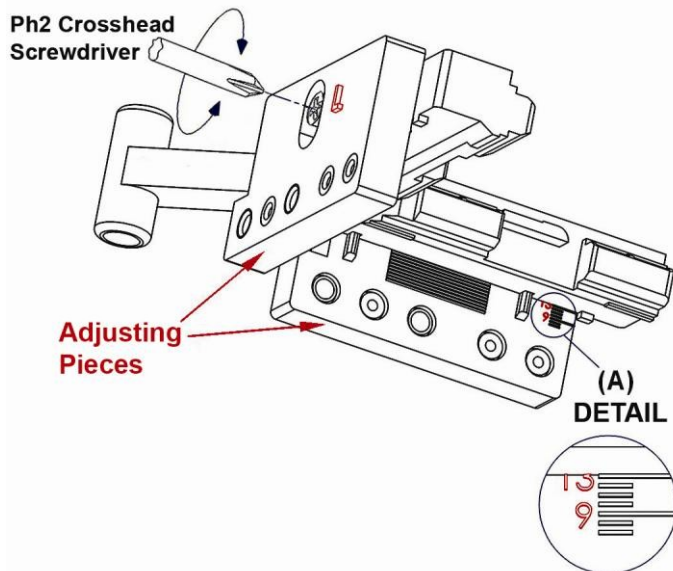

Termék Product	Termékkód Product Code
DRILLING JIG FOR DRILL IN CORNER HINGE HOLES	189110000

### Fúrósablon ollócsapágyhoz és sarokcsapágyhoz

Drilling Jig for Stay Arm Bearing & Corner Bearing Holes

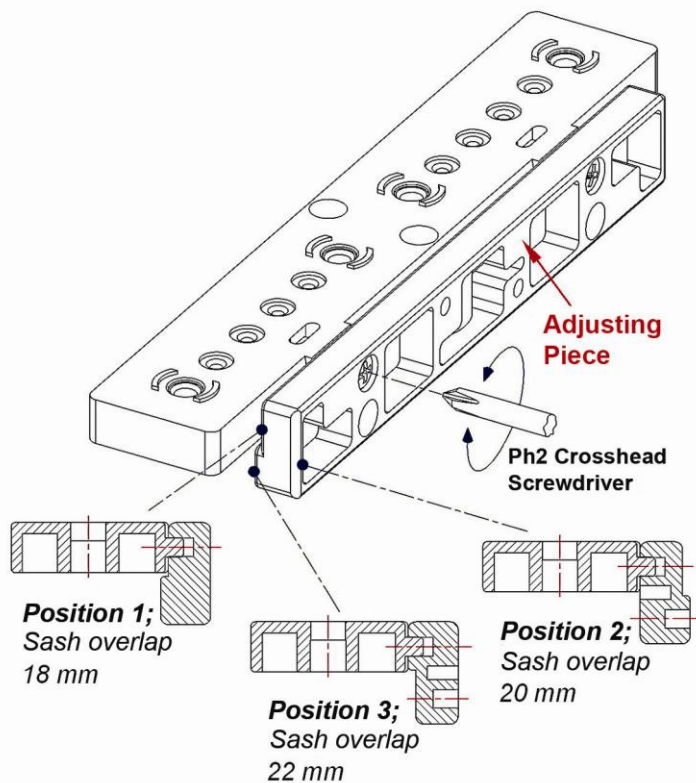

Termék Product	Termékkód Product Code
DRILLING JIG FOR STAY ARM BEARING & CORNER BEARING HOLES	189120000

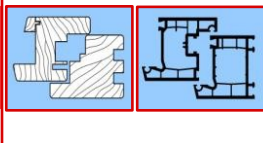

1301

## Hibásműködésgátó Faulty Usage

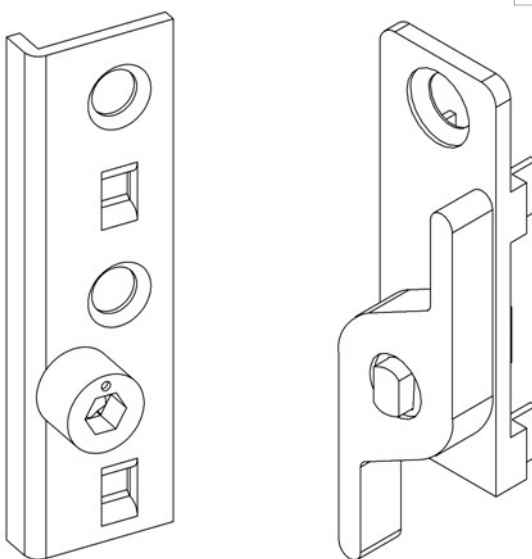
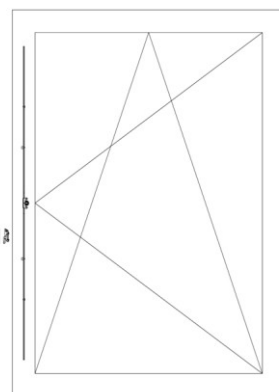
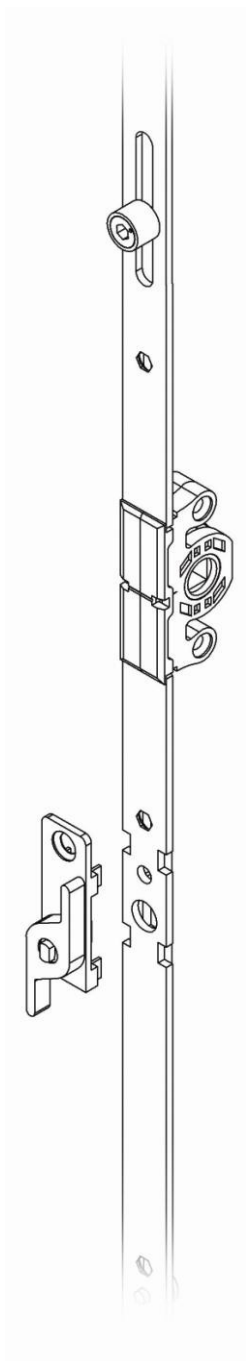

**Striker**

<b>Termék</b> Product	<b>Termékkód</b> Product Code
<b>FAULTY USAGE</b>	<b>189250001</b>

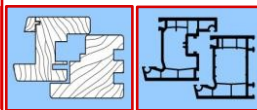

**1401**

**Bukó-nyíló készlet, festett**  
Painted T&T System Sets



181010001



184010001



189170001  
189160001



18603000\*



186120001



18608000\*  
18605000\*



18601000\*



18601000\*

<b>13-20 Painted T&amp;T System Sets</b>	<b>Termékkód</b> Product Code	<b>T&amp;T System</b> <b>Locking Plate</b>
13-20 Painted T&T System Set (Ral 9016)	189260013	189170001
13-20 Painted T&T System Set (Ral 8019)	189260014	189170001
13-20 Painted T&T System Set (Ral 8017)	189260015	189170001
13-20 Painted T&T System Set (Ral 8003)	189260016	189170001
13-20 Painted T&T System Set (Ral 1015)	189260017	189170001
13-20 Painted T&T System Set (Ral 8022)	189260018	189170001
13-20 Painted T&T System Set (Special)	18926001C	189170001

<b>9-20 Painted T&amp;T System Sets</b>	<b>Termékkód</b> Product Code	<b>T&amp;T System</b> <b>Locking Plate</b>
9-20 Painted T&T System Set (Ral 9016)	189270013	189160001
9-20 Painted T&T System Set (Ral 8019)	189270014	189160001
9-20 Painted T&T System Set (Ral 8017)	189270015	189160001
9-20 Painted T&T System Set (Ral 8003)	189270016	189160001
9-20 Painted T&T System Set (Ral 1015)	189270017	189160001
9-20 Painted T&T System Set (Ral 8022)	189270018	189160001
9-20 Painted T&T System Set (Special)	18927001C	189160001

Megjegyzés: A bukó-nyíló zárfogadók az ablakrendszerétől függően változhatnak!

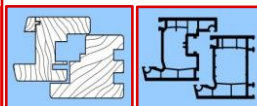

1402

## Bukó-nyíló készlet takaró elemekkel

T&T System Sets with Cover

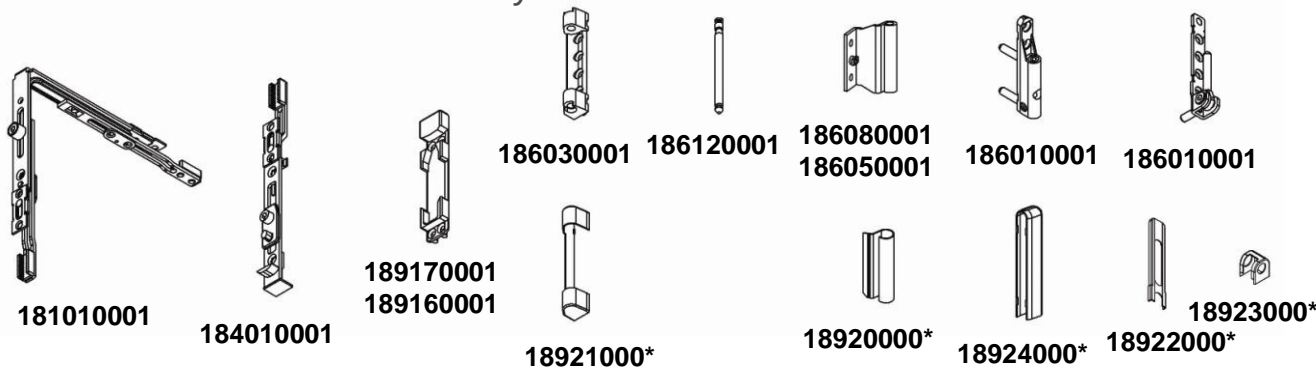

13-20 T&T System Sets with Cover	Termékkód Product Code	T&T System Locking Plate
13-20 T&T System Set with Cover (Ral 9016)	189280013	189170001
13-20 T&T System Set with Cover (Ral 8019)	189280014	189170001
13-20 T&T System Set with Cover (Ral 8017)	189280015	189170001
13-20 T&T System Set with Cover (Ral 8003)	189280016	189170001
13-20 T&T System Set with Cover (Ral 1015)	189280017	189170001
13-20 T&T System Set with Cover (Ral 8022)	189280018	189170001
13-20 T&T System Set with Cover (Special)	18928001C	189170001

13-20 T&T System Sets with Cover	Termékkód Product Code	T&T System Locking Plate
9-20 T&T System Set with Cover (Ral 9016)	189290013	189160001
9-20 T&T System Set with Cover (Ral 8019)	189290014	189160001
9-20 T&T System Set with Cover (Ral 8017)	189290015	189160001
9-20 T&T System Set with Cover (Ral 8003)	189290016	189160001
9-20 T&T System Set with Cover (Ral 1015)	189290017	189160001
9-20 T&T System Set with Cover (Ral 8022)	189290018	189160001
9-20 T&T System Set with Cover (Special)	18929001C	189160001

Megjegyzés: A bukó-nyíló zárfogadók az ablakrendszer-től függően változhatnak!



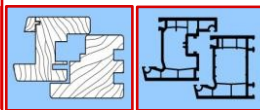

1403

## Biztonsági készlet

Under Security Sets

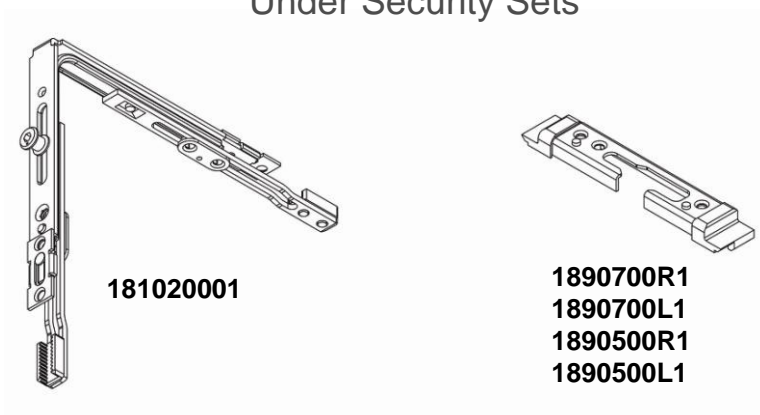

<b>Under Security Sets (13mm Sash overlap)</b>	<b>Termékkód</b> Product Code	<b>Security Locking Plate</b>
<b>Under Security Sets (13mm Sash overlap) -Right</b>	<b>189300011</b>	<b>1890700R1</b>
<b>Under Security Sets (13mm Sash overlap) -Left</b>	<b>189310011</b>	<b>1890700L1</b>

<b>Under Security Sets (9mm Sash overlap)</b>	<b>Termékkód</b> Product Code	<b>Security Locking Plate</b>
<b>Under Security Sets (9mm Sash overlap) -Right</b>	<b>189320011</b>	<b>1890500R1</b>
<b>Under Security Sets (9mm Sash overlap) -Left</b>	<b>189330011</b>	<b>1891500L1</b>